

SECTION 10

UTILUX EXPRESS

REFERENCE TABLES

TOOL SELECTION CHARTS

	PAGE
Utilux Express Order Forms	98-103
Non Metric Cable Conversion Tables	104
Useful Reference Tables	105-114
Termination Theory & Practices	115
Utilux Metric Coding System	116
Application Tooling Design Features	117



1. Tick a box to identify the standard blank which is closest to your required design.
2. Complete the Conductor Details section inserting your requirements.
3. Enter your required dimensions staying within the guidelines in the standards table.
4. Complete customer contact and authorisation details.
5. Fax to Utilux Express.

COPPER LUGS

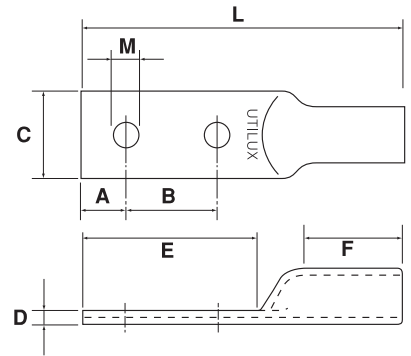
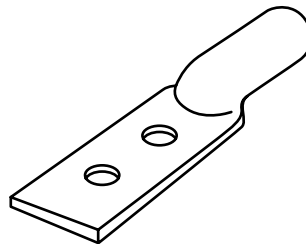

I. STANDARDS & GUIDELINES

All dimensions in mm

Catalogue No.	Conductor Range mm ²	A Min	B Max	C Ref	D Ref	E Max	F Max	L Max	M Max
<input type="checkbox"/> CGX25/I	25	8.0	54	16.7	1.9	70	40	115	M10
<input type="checkbox"/> CGX35/I	35	8.0	74	18.2	2.7	90	45	140	M12
<input type="checkbox"/> CGX50/I	50	11.0	78	20.6	2.8	100	50	159	M12
<input type="checkbox"/> CGX70/I	70	11.0	78	21.0	3.2	100	50	161	M12
<input type="checkbox"/> CGX 95/I	95	12.0	76	25.0	4.0	100	50	163	M12
<input type="checkbox"/> CGX120/I	120	15.0	70	30.0	4.8	100	50	165	M20
<input type="checkbox"/> CGX150/I	150	18.0	64	34.0	5.4	100	50	166	M20
<input type="checkbox"/> CGX185/I	185	18.0	64	37.0	5.2	100	55	173	M20
<input type="checkbox"/> CGX240/I	240	23.0	64	42.0	7.1	110	90	191	M20
<input type="checkbox"/> CGX300/I	300	23.0	64	46.0	7.9	110	90	192	M20
<input type="checkbox"/> CGX400/I	400	23.0	64	49.6	7.9	110	70	207	M20
<input type="checkbox"/> CGX500/I	500	23.0	64	54.8	8.2	110	70	213	M20
<input type="checkbox"/> CGX630/I	630	25.0	50	63.5	11.5	100	70	205	M20

2. CONDUCTOR DETAILS

3. REQUIRED SPECIFICATIONS

Stranding: _____

Area: _____ mm²

Type: Flexible

Solid

Stranded

Compacted

Dimensions: A: _____ mm B: _____ mm² E: _____ mm

F: _____ mm L: _____ mm Stud M: _____ mm

Qty: _____

Comments _____

4. CUSTOMER DETAILS

Company _____

Contact _____

Telephone _____

Facsimile _____

Order No. _____

Date _____

Approved By _____

Approval Signature _____

5. Fax this form to UTILUX EXPRESS - (02) 9554 3859

Specially manufactured products cannot be returned for credit.



COPPER LINKS

1. Tick a box to identify the standard blank which is closest to your required design.
2. Complete the Conductor Details section inserting your requirements.
3. Enter your required dimensions staying within the guidelines in the standards table.
4. Complete customer contact and authorisation details.
5. Fax to Utilux Express.

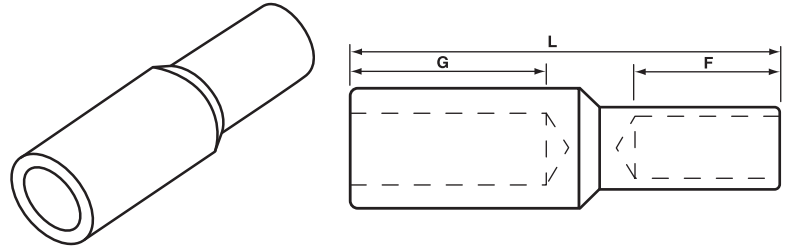

I. STANDARDS & GUIDELINES All dimensions in mm

Catalogue No.	Conductor Range mm ²	F Recommended Lengths	G
<input type="checkbox"/> CKX10-35/I	10-35	24	24
<input type="checkbox"/> CKX50-70/I	50-70	24	24
<input type="checkbox"/> CKX95-120/I	95-120	38	38
<input type="checkbox"/> CKX150-185/I	150-185	38	38
<input type="checkbox"/> CKX240-300/I	240-300	44	44
<input type="checkbox"/> CKX400-500/I	400-500	59	59
<input type="checkbox"/> CKX630/I	630	59	59

2. CONDUCTOR DETAILS ▶ 3. REQUIRED SPECIFICATIONS

LARGE END	SMALL END	Dimensions: F: _____mm G: _____mm
Stranding: _____	Stranding: _____	Qty: _____
Area : _____mm ²	Area: _____mm ²	
Type: Flexible <input type="checkbox"/> Solid <input type="checkbox"/> Stranded <input type="checkbox"/> Compacted <input type="checkbox"/>		Comments _____ _____

4. CUSTOMER DETAILS

Company _____	Order No. _____
Contact _____	Date _____
Telephone _____	Approved By _____
Facsimile _____	Approval Signature _____

5. Fax this form to **UTILUX EXPRESS - (02) 9554 3859**

Specially manufactured products cannot be returned for credit.



1. Tick a box to identify the standard blank which is closest to your required design.
2. Complete the Conductor Details section inserting your requirements.
3. Enter your required dimensions staying within the guidelines in the standards table.
4. Complete customer contact and authorisation details.
5. Fax to Utilux Express.

BI-METAL LINKS

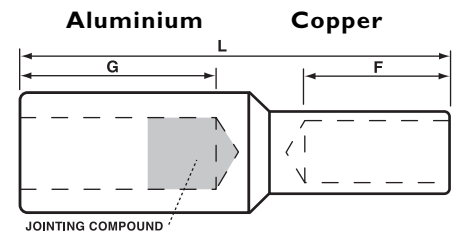
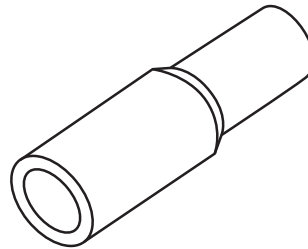

I. STANDARDS & GUIDELINES All dimensions in mm

Catalogue No.	Conductor Range mm ²	F Max	G Max	L Max
<input type="checkbox"/> BKX10-35/I	10-35	21.5	32	70
<input type="checkbox"/> BKX50-70/I	50-70	21.5	32	70
<input type="checkbox"/> BKX95-120/I	95-120	40	60	120
<input type="checkbox"/> BKX150-185/I	150-185	40	60	120
<input type="checkbox"/> BKX240-300/I	240-300	40	60	120
<input type="checkbox"/> BKX400-630/I	400-630	60	70	160

2. CONDUCTOR DETAILS 3. REQUIRED SPECIFICATIONS

LARGE END Material: Al Stranding: _____ Area : _____mm ²	SMALL END Material: Cu Stranding: _____ Area: _____mm ²	Dimensions: F: _____mm G: _____mm Qty: _____ Comments _____ _____ _____
Type: Flexible <input type="checkbox"/> Solid <input type="checkbox"/> Stranded <input type="checkbox"/> Compacted <input type="checkbox"/>		

4. CUSTOMER DETAILS

Company _____	Order No. _____
Contact _____	Date _____
Telephone _____	Approved By _____
Facsimile _____	Approval Signature _____

5. Fax this form to **UTILUX EXPRESS - (02) 9554 3859**

Specially manufactured products cannot be returned for credit.



1. Tick a box to identify the standard blank which is closest to your required design.
2. Complete the Conductor Details section inserting your requirements.
3. Enter your required dimensions staying within the guidelines in the standards table.
4. Complete customer contact and authorisation details.
5. Fax to Utilux Express.

ALUMINIUM LINKS

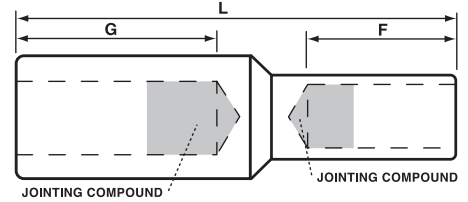
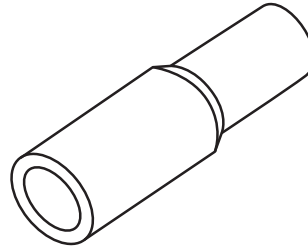

I. STANDARDS & GUIDELINES All dimensions in mm

Catalogue No.	Conductor Range mm ²	F Recommended Lengths	G
<input type="checkbox"/> AKX10-35/I	10-35	32	32
<input type="checkbox"/> AKX50-70/I	50-70	32	32
<input type="checkbox"/> AGX95-120/I	95-120	60	60
<input type="checkbox"/> AKX150-185/I	150-185	60	60
<input type="checkbox"/> AKX240-300/I	260-300	60	60
<input type="checkbox"/> AKX400-630/I	400-630	70	70

2. CONDUCTOR DETAILS ▶ 3. REQUIRED SPECIFICATIONS

LARGE END	SMALL END	Dimensions: F: _____ mm G: _____ mm
Stranding: _____	Stranding: _____	Qty: _____
Area: _____ mm ²	Area: _____ mm ²	Comments
Type: Flexible <input type="checkbox"/>		_____
Solid <input type="checkbox"/>		_____
Stranded <input type="checkbox"/>		
Compacted <input type="checkbox"/>		

4. CUSTOMER DETAILS

Company _____	Order No. _____
Contact _____	Date _____
Telephone _____	Approved By _____
Facsimile _____	Approval Signature _____

5. Fax this form to UTILUX EXPRESS - (02) 9554 3859

Specially manufactured products cannot be returned for credit.



1. Tick a box to identify the standard blank which is closest to your required design.
2. Complete the Conductor Details section inserting your requirements.
3. Enter your required dimensions staying within the guidelines in the standards table.
4. Complete customer contact and authorisation details.
5. Fax to Utilux Express.

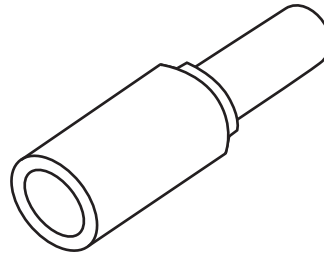

BI-METAL STALK LUGS

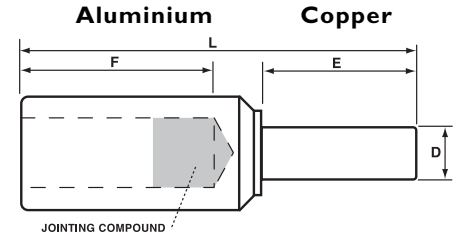

I. STANDARDS & GUIDELINES

All dimensions in mm

Catalogue No.	Conductor Range mm ²	D Max	E Max	F Max	L Max
<input type="checkbox"/> BSX10-35/I	10-35	12	30	32	70
<input type="checkbox"/> BSX50-70/I	50-70	16	30	32	70
<input type="checkbox"/> BSX95-120/I	95-120	22	50	60	120
<input type="checkbox"/> BSX150-185/I	150-185	26	50	60	120
<input type="checkbox"/> BSX240-300/I	240-300	33	50	60	120
<input type="checkbox"/> BSX400-630/I	400-630	45	70	70	160

2. CONDUCTOR DETAILS

3. REQUIRED SPECIFICATIONS

LARGE END	SMALL END	Dimensions: D: _____mm E: _____mm F: _____mm
Material: Al	Material: Cu	
Stranding: _____		Qty: _____
Area : _____mm ²	Diameter : _____mm	Comments
Type: Flexible <input type="checkbox"/>		_____
Solid <input type="checkbox"/>		_____
Stranded <input type="checkbox"/>		_____
Compacted <input type="checkbox"/>		_____

4. CUSTOMER DETAILS

Company	Order No.
_____	_____
Contact	Date
_____	_____
Telephone	Approved By
_____	_____
Facsimile	Approval Signature
_____	_____

5. Fax this form to **UTILUX EXPRESS - (02) 9554 3859**

Specially manufactured products cannot be returned for credit.



COPPER STALK LUGS

1. Tick a box to identify the standard blank which is closest to your required design.
2. Complete the Conductor Details section inserting your requirements.
3. Enter your required dimensions staying within the guidelines in the standards table.
4. Complete customer contact and authorisation details.
5. Fax to Utilux Express.

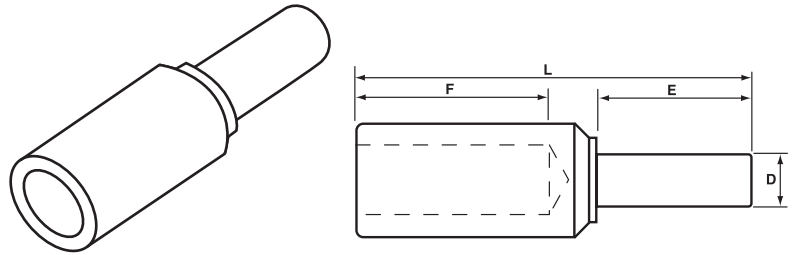

I. STANDARDS & GUIDELINES All dimensions in mm

Catalogue No.	Conductor Range mm ²	D Max	E Max	F Recommended
<input type="checkbox"/> CSX10-35/I	10-35	12	50	21.5
<input type="checkbox"/> CSX50-70/I	50-70	16	50	21.5
<input type="checkbox"/> CSX95-120/I	95-120	22	50	35
<input type="checkbox"/> CSX150-185/I	150-185	26	70	35
<input type="checkbox"/> CSX240-300/I	240-300	33	90	50
<input type="checkbox"/> CSX400-500/I	400-500	39	100	60

2. CONDUCTOR DETAILS ▶ 3. REQUIRED SPECIFICATIONS

LARGE END Material: Cu Stranding: _____ Area : _____mm ²	SMALL END Material: Cu Diameter : _____mm	Dimensions: D: _____mm E: _____mm F: _____mm Qty: _____ Comments _____ _____ _____
Type: Flexible <input type="checkbox"/> Solid <input type="checkbox"/> Stranded <input type="checkbox"/> Compacted <input type="checkbox"/>		

4. CUSTOMER DETAILS

Company _____	Order No. _____
Contact _____	Date _____
Telephone _____	Approved By _____
Facsimile _____	Approval Signature _____

5. Fax this form to **UTILUX EXPRESS - (02) 9554 3859**

Specially manufactured products cannot be returned for credit.

CONVERSION TABLES FOR NON-METRIC CABLE SIZES

BRITISH STANDARD WIRE GAUGE SWG	METRIC EQUIVALENT (sqmm)
33	0.0507
32	0.0591
31	0.0682
30	0.0779
29	0.0937
28	0.0111
27	0.0136
26	0.0164
25	0.0203
24	0.0245
23	0.0292
22	0.0397
21	0.0519
20	0.0657
19	0.81
18	1.17
17	1.59
16	2.08
15	2.63
14	3.24
13	4.29
12	5.48
10	8.30

IMPERIAL (sqIN)	METRIC EQUIVALENT (sqmm)
0.001	0.657
0.0015	0.981
0.002	1.28
0.003	1.97
0.0032	2.08
0.0045	2.98
0.007	4.60
0.01	6.81
0.0145	9.59
0.0225	14.5
0.03	18.6
0.04	26.0
0.06	39.4
0.075	49.9
0.1	66.3
0.12	76.8
0.15	97.2
0.2	129
0.25	162
0.3	199
0.4	267
0.5	328
0.6	399
0.75	489
0.85	557
1.0	683
1.25	807
1.5	1050

AMERICAN WIRE GAUGE AWG	METRIC EQUIVALENT (sqmm)	AMERICAN WIRE GAUGE AWG	METRIC EQUIVALENT (sqmm)
30	0.0507	250 MCM	127
29	0.0645	300 MCM	152
28	0.0806	350 MCM	177
27	0.102	400 MCM	203
26	0.128	450 MCM	228
25	0.163	500 MCM	253
24	0.205	550 MCM	279
23	0.259	600 MCM	304
22	0.324	650 MCM	329
21	0.412	700 MCM	355
20	0.519	750 MCM	380
19	0.652	800 MCM	405
18	0.826	850 MCM	431
17	1.04	900 MCM	456
16	1.31	950 MCM	481
15	1.65	1000 MCM	507
14	2.08	1100 MCM	557
13	2.63	1200 MCM	608
12	3.31	1300 MCM	659
11	4.17	1400 MCM	709
10	5.26	1500 MCM	760
9	6.63	1600 MCM	811
8	8.37	1700 MCM	861
7	10.6	1800 MCM	912
6	13.3	1900 MCM	963
5	16.8	2000 MCM	1010
4	21.2		
3	26.7		
2	33.6		
1	42.4		
0	53.5		
2/0	67		
3/0	85		
4/0	107		

USEFUL REFERENCE TABLES

APPENDIX A

FITTINGS FOR BARE OVERHEAD ALL ALUMINIUM CONDUCTORS (AAC)

CODE NAME	STRAND	NON TENSION		FULL TENSION		JUMPER		ALUMINIUM LUG		ALUMINIUM LUG		TERM. ADAPTOR		BI-METAL LUG	
		SLEEVE	DIE	SLEEVE	DIE	SLEEVE	DIE	1 HOLE	DIE	2 HOLE	DIE	TYPE	DIE		DIE
Gemini	7/1.75	NT36	38-132AL	FT36A	38-132AL	JS36R	38-132AL	SL36	38-132AL	AL36	38-132AL	BA36	38-132AL	H15304	38-90AL
Jupiter	7/2.25	NT36	38-140AL	FT36A	38-140AL	JS36R	38-140AL	SL36	38-140AL	AL36	38-140AL	BA36	38-140AL	H15306	38-90AL
Leo	7/2.50	NT36	38-140AL	FT36A	38-140AL	JS36R	38-140AL	SL36	38-140AL	AL36	38-140AL	BA36	38-140AL	H15308	38-90AL
Leondis	7/2.75	NT44	38-173AL	FT44A	38-173AL	JS44R	38-173AL	SL44	38-173AL	AL44	38-173AL			H15308	38-90AL
Libra	7/3.00	NT44	38-180AL	FT44A	38-173AL	JS44R	38-180AL	SL44	38-180AL	AL44	38-180AL			H15311	38-132AL
Mars	7/3.75	NT50	38-180AL	FT50A	38-180AL	JS50R	38-180AL	SL50	38-180AL	AL50	38-180AL	BA50	38-180AL	H15317	38-173AL
Mercury	7/4.50	NT58	38-190AL	FT58A	38-190AL	JS58R	38-190AL	SL58	38-190AL	AL58	38-190AL	BA58	38-190AL	H15320	38-173AL
Mercury	7/4.50	NT61	38-220AL	FT61A	38-220AL	JS61R	38-220AL	SL61	38-220AL	AL61	38-220AL	BA61	38-220AL	H15320	38-173AL
Moon	7/4.75	NT61	38-220AL	FT61A	38-220AL	JS61R	38-220AL	SL61	38-220AL	AL61	38-220AL	BA61	38-220AL	H15320	38-173AL
Neptune	19/3.25	NT68	38-220AL	FT68A	38-220AL	JS68R	38-220AL	SL68	38-220AL	AL68	38-220AL	BA68	38-220AL	H15323	38-220AL
Orion	19/3.50	NT80	38-250AL	FT80A	38-250AL	JS80R	38-250AL	SL80	38-250AL	AL80	38-250AL	BA80	38-250AL	H15326	38-220AL
Pluto	19/3.75	NT80	38-262AL	FT80A	38-262AL	JS80R	38-262AL	SL80	38-262AL	AL80	38-262AL	BA80	38-262AL	H15329	38-284AL
Saturn	37/3.00	NT94	38-284AL	FT94A	38-284AL	JS94R	38-284AL	SL94	38-284AL	AL94	38-284AL			H15332	38-284AL
Sirius	37/3.25	NT94	38-284AL	FT94A	38-284AL	JS94R	38-284AL	SL94	38-284AL	AL94	38-284AL			H15332	38-284AL
Taurus	19/4.75	NT94	38-303AL	FT94A	38-303AL	JS94R	38-303AL	SL94	38-303AL	AL94	38-303AL			H15334	38-390AL
Triton	37/3.75	NT114	40-432AL	FT114A	40-432AL										

FITTINGS FOR BARE OVERHEAD ALUMINIUM CONDUCTORS STEEL REINFORCED (ACSR)

CODE NAME	STRAND	NON TENSION		FULL TENSION		JUMPER		ALUMINIUM LUG		ALUMINIUM LUG		TERM. ADAPTOR		BI-METAL LUG	
		SLEEVE	DIE	SLEEVE	DIE	SLEEVE	DIE	1 HOLE	DIE	2 HOLE	DIE	TYPE	DIE		DIE
Quince	3/4/1.75	NT36	38-132AL			JS36R	38-132AL	SL36	38-132AL	AL36	38-132AL	BA36	38-132AL	H15304	38-90AL
Almond	6/1/2.50	NT36	38-140AL	FT36R	38-140AL	JS36R	38-140AL	SL36	38-140AL	AL36	38-140AL	BA36	38-140AL	H15308	38-90AL
Raisin	3/4/2.50	NT36	38-140AL			JS36R	38-140AL	SL36	38-140AL	AL36	38-140AL	BA36	38-140AL	H15308	38-90AL
Apricot	6/1/2.75	NT44	38-173AL	FT44R	38-173AL	JS44R	38-173AL	SL44	38-173AL	AL44	38-173AL	BA44	38-173AL	H15308	38-90AL
Apple	6/1/3.00	NT44	38-173AL	FT44R	38-173AL	JS44R	38-173AL	SL44	38-173AL	AL44	38-173AL	BA44	38-173AL	H15311	38-132AL
Sultana	4/3/3.00	NT44	38-180AL			JS44R	38-180AL	SL44	38-180AL	AL44	38-180AL	BA44	38-180AL	H15311	38-132AL
Banana	6/1/3.75	NT50	38-180AL	FT50R	38-180AL	JS50R	38-180AL	SL50	38-180AL	AL50	38-180AL	BA50	38-180AL	H15317	38-173AL
Walnut	4/3/3.75	NT50	38-180AL			JS50R	38-180AL	SL50	38-180AL	AL50	38-180AL	BA50	38-180AL	H15317	38-173AL
Cherry	6/4.75 7/1.60	NT61	38-220AL	FT61R	38-220AL	JS61R	38-220AL	SL61	38-220AL	AL61	38-220AL	BA61	38-220AL	H15320	38-173AL
Grape	30/7/2.50	NT80	38-250AL			JS80R	38-250AL	SL80	38-250AL	AL80	38-250AL			H15326	38-220AL
Fig	18/1/3.50	NT80	38-250AL	FT80R	38-250AL	JS80R	38-250AL	SL80	38-250AL	AL80	38-250AL			H15326	38-220AL
Lemon	30/7/3.00	NT94	38-284AL												

USEFUL REFERENCE TABLES

AUSTRALIAN STANDARD METRIC CONDUCTORS

ACSR/AC – ALUMINIUM CONDUCTOR (ALUMINIUM CLAD) STEEL REINFORCED.

Aust. Standard – AS1220 PART 3

CODE NAME	STRANDS/ WIRE DIAMETER mm	OVERALL DIAMETER (APPROX) mm	CALCULATED EQUIVALENT ALUMINIUM AREA mm ²	SECTIONAL AREA mm ²	CALCULATED MINIMUM BREAKING LOAD kN	APPROXIMATE MASS PER KM kg
Angling	6/1/2.50	7.50	30.7	34.36	10.7	113
Archery	6/1/3.00	9.00	44.1	49.48	15.0	163
Baseball	6/1/3.75	11.3	68.9	77.31	22.4	255
Bowls	6/4.75+7/1.60	14.3	109	120.4	32.6	385
Cricket	30/7/2.50	17.5	155	181.6	64.6	635
Darts	30/7/3.00	21.0	224	261.5	91.3	913
Diving	30/7/3.50	24.5	305	356.0	121	1240
Golf	54/7/3.00	27.0	390	431.2	119	1380
Gymnastics	54/7/3.25	29.3	457	506.0	138	1620
Hurdles	54/7/3.50	31.5	530	586.9	159	1880
Lacrosse	54/3.75+19/2.25	33.8	608	671.7	181	2150
Rugby	54/4.75+19/2.85	42.8	976	1078	287	3450
EXTRA HIGH STRENGTH						
Skating	3/4/1.75	5.25	10.4	16.84	12.3	83.5
Soccer	3/4/2.50	7.50	21.2	34.36	24.9	170
Swimming	4/3/3.00	9.00	35.2	49.48	28.8	217
Tennis	4/3/3.75	11.3	54.9	77.31	42.8	339



USEFUL REFERENCE TABLES

AUSTRALIAN STANDARD METRIC CONDUCTORS

AAC – ALL ALUMINIUM CONDUCTOR

Aust. Standard – AS1531 PART 1

CODE NAME	STRANDS/ WIRE DIAMETER mm	OVERALL DIAMETER (APPROX) mm	CALCULATED EQUIVALENT ALUMINIUM AREA mm ²	SECTIONAL AREA mm ²	CALCULATED MINIMUM BREAKING LOAD kN	APPROXIMATE MASS PER KM kg
Gemini	7/1.75	5.25	16.6	16.84	3.01	46.1
Jupiter	7/2.25	6.75	27.5	27.83	4.76	75.9
Leo	7/2.50	7.50	33.9	34.36	5.75	94.3
Libra	7/3.00	9.00	48.8	49.48	7.91	135
Mars	7/3.75	11.3	76.3	77.31	11.9	212
Mercury	7/4.50	13.5	110	111.3	16.8	305
Moon	7/4.75	14.3	122	124.0	18.8	340
Neptune	19/3.25	16.3	155	157.6	24.7	433
Pluto	19/3.75	18.8	206	209.8	32.3	578
Saturn	37/3.00	21.0	256	261.5	41.8	721
Taurus	19/4.75	23.8	331	336.7	50.9	926
Triton	37/3.75	26.3	400	408.7	62.9	1130
Uranus	61/3.25	29.3	493	506.0	75.2	1400
Venus	61/3.75	33.8	659	673.7	98.3	1860
Virgo	91/4.50	49.5	1410	1447	207	4010

AAAC – ALL ALUMINIUM ALLOY CONDUCTOR

Aust. Standard – AS1531 PART 2

CODE NAME	STRANDS/ WIRE DIAMETER mm	OVERALL DIAMETER (APPROX) mm	CALCULATED EQUIVALENT ALUMINIUM AREA mm ²	SECTIONAL AREA mm ²	CALCULATED MINIMUM BREAKING LOAD kN	APPROXIMATE MASS PER KM kg
Agate	7/1.75	5.25	14.3	16.84	4.71	46.1
Amethyst	7/2.25	6.75	23.7	27.83	7.78	75.9
Diamond	7/2.50	7.50	29.3	34.36	9.64	94.3
Emerald	7/3.00	9.00	42.1	49.48	13.9	135
Garnet	7/3.75	11.3	65.8	77.31	21.7	211
Jade	7/4.50	13.5	94.8	111.3	31.2	304
Jasper	7/4.75	14.3	106	124.0	34.8	339
Opal	19/3.25	16.3	134	157.6	44.2	433
Pearl	19/3.75	18.8	178	209.8	58.8	576
Ruby	37/3.00	21.0	221	261.5	73.5	721
Rutile	19/4.75	23.8	285	336.7	94.4	924
Sapphire	37/3.75	26.3	345	408.7	115	1120
Spinel	61/3.25	29.3	426	506.0	135	1400
Topaz	61/3.75	33.8	568	673.7	179	1860
Zircon	91/4.50	49.5	1220	1447	384	4000

USEFUL REFERENCE TABLES

AUSTRALIAN STANDARD METRIC CONDUCTORS

SC/GZ – STEEL CONDUCTOR/GALVANISED

Aust. Standard – AS1222 PART 1

STRANDS/WIRE DIAMETER /mm	OVERALL DIAMETER (APPROX) mm	CALCULATED EQUIV. ALUMINIUM AREA mm ²	SECTIONAL AREA mm ²	CALCULATED MIN. BREAKING LOAD kN	APPROXIMATE MASS PER Km kg
3/2.00	4.31	1.56	9.425	11.7	75.5
3/2.75	5.93	2.95	17.82	22.2	139
7/2.00	6.00	3.62	21.99	27.4	177
7/2.75	8.25	6.85	41.58	51.8	326
7/3.25	9.75	9.56	58.07	72.3	460
7/3.75	11.3	12.7	77.31	96.2	609
19/2.00	10.0	9.79	59.69	74.4	483
19/2.75	13.8	18.5	112.9	141.0	888
19/3.25	16.3	25.8	157.6	196.0	1250

SC/AC – STEEL CONDUCTOR/ALUMINIUM CLAD

Aust. Standard – AS1222 PART 2

STRANDS/WIRE DIAMETER /mm	OVERALL DIAMETER (APPROX) mm	CALCULATED EQUIV. ALUMINIUM AREA mm ²	SECTIONAL AREA mm ²	CALCULATED MIN. BREAKING LOAD kN	APPROXIMATE MASS PER Km kg
3/2.75	5.93	5.91	17.82	22.7	118
3/3.00	6.47	7.03	21.21	27.0	141
3/3.25	7.00	8.26	24.89	31.6	165
3/3.75	8.08	11.0	33.13	40.0	220
7/2.75	8.25	13.7	41.58	50.1	277
7/3.00	9.00	16.3	49.48	59.7	330
7/3.25	9.75	19.2	58.07	69.8	387
7/3.75	11.3	25.5	77.31	88.3	515
7/4.25	12.8	32.8	99.3	106	662
19/2.75	13.8	37.1	112.9	136	755
19/3.00	15.0	44.1	134.3	162	899
19/3.25	16.3	51.8	157.6	189	1060
19/3.75	18.8	68.9	209.8	240	1410
19/4.25	21.3	88.6	269.5	289	1800

HDC – HARD DRAWN COPPER CONDUCTOR

Aust. Standard – AS1746 1975

STRANDS/WIRE DIAMETER /mm	OVERALL DIAMETER (APPROX) mm	CALCULATED EQUIV. ALUMINIUM AREA mm ²	SECTIONAL AREA mm ²	CALCULATED MIN. BREAKING LOAD kN	APPROXIMATE MASS PER Km kg
7/1.00	3.00	8.68	5.498	2.31	49.3
7/1.25	3.75	13.6	8.589	3.61	76.9
7/1.75	5.25	26.6	16.84	6.89	151
7/2.00	6.00	34.7	21.99	9.02	197
7/2.75	8.25	65.3	41.58	16.7	375
7/3.50	10.5	106	67.35	26.6	607
19/1.75	8.75	71.7	45.70	18.3	413
19/2.00	10.0	93.7	59.69	23.9	538
19/2.75	13.8	177	112.9	44.5	1020
19/3.00	15.0	211	134.3	52.8	1210
37/1.75	12.3	139	89.0	35.6	806
37/2.50	17.5	284	181.6	72.9	1640
37/2.75	19.3	344	219.8	86.6	1990
37.3.00	21.0	409	261.5	103	2370
61/2.75	24.8	566	362.3	143	3280

USEFUL REFERENCE TABLES

AUSTRALIAN STANDARD METRIC CONDUCTORS

ACSR/GZ – ALUMINIUM CONDUCTOR (GALVANISED) STEEL REINFORCED.

Aust. Standard – AS1220 PART 1

CODE NAME	STRANDS/ WIRE DIAMETER mm	OVERALL DIAMETER (APPROX) mm	CALCULATED EQUIVALENT ALUMINIUM AREA mm ²	SECTIONAL AREA mm ²	CALCULATED MINIMUM BREAKING LOAD kN	APPROXIMATE MASS PER KM kg
Almond	6/1/2.50	7.50	29.0	34.36	10.5	119
Apple	6/1/3.00	9.00	41.8	49.48	14.9	171
Banana	6/1/3.75	11.3	65.2	77.31	22.8	268
Cherry	6/4.75 + 7/1.60	14.3	105	120.4	33.2	404
Grape	30/7/2.50	17.5	144	181.6	63.7	675
Lemon	30/7/3.00	21.0	207	261.5	90.1	973
Lime	30/7/3.50	24.5	282	356.0	121	1320
Mango	54/7/3.00	27.0	373	431.2	118	1440
Orange	54/7/3.25	29.3	438	506.0	137	1690
Olive	54/7/3.50	31.5	508	586.9	159	1960
Paw Paw	54/3.75 + 19/2.25	33.8	583	671.7	179	2250
Peach	54/4.75 + 19/2.85	42.8	936	1078	284	3600
EXTRA HIGH STRENGTH						
Quince	3/4/1.75	5.25	8.77	16.84	12.7	95.9
Raisin	3/4/2.50	7.50	17.9	34.36	24.4	193
Sultana	4/3/3.00	9.00	31.6	49.48	28.3	242
Walnut	4/3/3.75	11.3	49.4	77.31	43.9	379

ACSR/AZ – ALUMINIUM CONDUCTOR (ALUMINISED) STEEL REINFORCED.

Aust. Standard – AS1220 PART 2

CODE NAME	STRANDS/ WIRE DIAMETER mm	OVERALL DIAMETER (APPROX) mm	CALCULATED EQUIVALENT ALUMINIUM AREA mm ²	SECTIONAL AREA mm ²	CALCULATED MINIMUM BREAKING LOAD kN	APPROXIMATE MASS PER KM kg
Barley	6/1/2.50	7.50	29.0	34.36	10.3	119
Bean	6/1/3.00	9.00	41.8	49.48	14.5	171
Cabbage	6/1/3/75	11.3	65.2	77.31	21.5	268
Carrot	6/4.75 + 7/1.60	14.3	105	120.4	31.9	404
Corn	30/7/2.50	17.5	144	181.6	61.6	675
Garlic	30/7/3.00	21.0	207	261.5	87.2	973
Millet	30/7/3.50	24.5	282	356.0	116	1320
Oats	54/7/3.00	27.0	373	431.2	115	1140
Onion	54/7/3.25	29.3	438	506.0	132	1690
Parsnip	54/7/3.50	31.5	508	586.9	153	1960
Potato	54/3.75 + 19/2.25	33.8	583	671.7	177	2250
Rice	54/4.75 + 19/2.85	42.8	936	1078	277	3600

USEFUL REFERENCE TABLES

A.C.S.R. CONDUCTOR SIZES

METRIC			IMPERIAL		
CODE NAME	STRANDING	CONDUCTOR O.D. mm inches	CODE NAME	STRANDING	O.D. inches
Almond	6/2.50 + 1/2.50	7.50 .295	Gopher	6/1/093	.279
Apple	6/3.00 + 1/3.00	9.00 .354	Ferret	6/1/118	.354
Banana	6/3.75 + 1/3.75	11.3 .445	Mink	6/1/144	.432
Cherry	6/4.75 + 7/1.60	14.3 .563	Dog	6/186 + 7/062	.558
Grape	30/2.50 + 7/2.50	17.5 .689	Wolf	30/7/102	.714
Lemon	30/3.00 + 7/3.00	21.0 .827	Panther	30/7/118	.826
Lime	30/3.50 + 7/3.50	24.5 .965	Bear	30/7/132	.924
Mango	54/3.00 + 7/3.00	27.0 1.063	Bison	54/7/118	1.062
Orange	54/3.25 + 7/3.25	29.3 1.154	Brolga	54/7/129	1.162
Olive	54/3.50 + 7/3.50	31.5 1.240	Moose	54/7/139	1.251
Paw Paw	54/3.75 + 19/2.25	33.8 1.331	Finch	54/143 + 19/086	1.293

STRANDED HARD DRAWN COPPER CONDUCTOR SIZES

METRIC			IMPERIAL		
CODE NAME	CONDUCTOR O.D.		CODE NAME	CONDUCTOR O.D.	
	mm	inches		mm	inches
7/1.00	3.00	.118	7/036	2.7	.108
7/1.25	3.75	.148	7/048	3.7	.144
7/1.75	5.25	.207	7/064	4.9	.192
7/2.0	6.00	.236	7/080	6.1	.240
7/2.75	8.25	.325	19/064	8.1	.320
19/1.75	8.75	.345	7/118	9.0	.354
19/2.0	10.0	.394	7/136	10.3	.408
7/3.50	10.5	.413	19/083	10.5	.415
37/1.75	12.25	.484	37/072	12.8	.504
19/2.75	13.75	.541	-	-	-
19/3.00	15.0	.591	19/116	14.7	.580
37/2.50	17.5	.689	37/093	16.5	.651
37/2.75	19.25	.758	37/103	18.3	.721
37/3.00	21.0	.827	37/118	21.0	.826
61/2.75	24.75	.974	91/093	26.0	1.023

USEFUL REFERENCE TABLES

CABLE CROSS SECTIONS

ANNEALED ALUMINIUM AND COPPER STRANDED CONDUCTORS

METRIC			IMPERIAL				
NOMINAL CROSS SECTIONAL AREA mm ²	NUMBER AND NOMINAL DIA. OF WIRES mm	NOMINAL DIA. OF CONDUCTOR mm	NOMINAL CROSS SECTIONAL AREA mm ²	NUMBER AND NOMINAL DIA. OF WIRES		NOMINAL CROSS SECTIONAL AREA inches ²	NOMINAL DIA. OF CONDUCTOR mm
				inches	mm		
1	1/1.13	1.13	.97	1/.044	1/1.12	.0015	1.12
-	-	-	1.25	3/.029	3/.737	.0019	1.59
1.5	1/1.38	1.38	-	-	-	-	-
-	-	-	1.93	3/.036	3/.914	.003	1.97
2.5	7/0.67	2.01	-	-	-	-	-
-	-	-	2.93	7/.029	7/.737	.0045	2.21
4	7/0.85	2.55	-	-	-	-	-
-	-	-	4.52	7/.036	7/.914	.007	2.74
6	7/1.04	3.12	-	-	-	-	-
-	-	-	6.75	7/.044	7/1.12	.010	3.35
-	-	-	9.43	7/.052	7/1.32	.0146	3.96
10	7/1.35	4.05	-	-	-	-	-
-	-	-	14.28	7/.064	7/1.63	.0025	4.88
16	7/1.70	5.10	-	-	-	-	-
-	-	-	18.29	19/.044	19/1.12	.03	5.59
25	7/2.14	6.75	25.5	19/.052	19/1.32	.04	6.60
35	19/1.53	7.65	-	-	-	-	-
-	-	-	38.7	19/.064	19/1.63	.06	8.13
50	19/1.78	8.90	-	-	-	-	-
-	-	-	65.1	19/.083	19/2.11	.10	10.5
70	19/2.14	10.70	-	-	-	-	-
-	-	-	75.3	37/.064	37/1.63	.12	11.4
95	19/2.52	12.60	95.3	37/.072	37/1.83	.15	12.8
120	37/2.03	14.21	126.7	37/.083	37/2.11	.20	14.8
150	37/2.25	15.75	-	-	-	-	-
-	-	-	159.1	37/.093	37/2.36	.25	16.5
185	37/2.52	17.64	-	-	-	-	-
-	-	-	195.1	37/.103	37/2.62	.30	18.3
240	61/2.25	20.25	-	-	-	-	-
-	-	-	262.2	61/.093	61/2.36	.40	21.3
300	61/2.52	22.68	-	-	-	-	-
-	-	-	321.6	61/.103	61/2.62	.50	23.5
-	-	-	391.1	91/.093	91/2.36	.60	26.0
400	61/2.85	25.65	-	-	-	-	-
-	-	-	479.7	91/.103	91/2.62	.75	28.8
500	61/3.20	28.80	-	-	-	-	-
630	127/2.52	32.76	-	-	-	-	-
-	-	-	669.4	127/.103	127/2.62	1.00	34.0
800	127/2.85	37.05	800.00	127/.112	127/2.84	1.24	36.92
1000	127/3.20	41.60	1000.0	127/.125	127/3.18	1.50	41.34

USEFUL REFERENCE TABLES

OVERHEAD CONDUCTORS

AAC				AAAC (1120)				AAAC (6201A)				ACSR			
CODE	STRAND AL	O.D. mm	AREA mm ²	CODE	STRAND AL	O.D. mm	AREA mm ²	CODE	STRAND AL	O.D. mm	AREA mm ²	CODE	STRAND AL	O.D. mm	AREA mm ²
Gemini	7/1.75	5.25	16.8	Argon	7/1.75	5.25	16.8	Agate	7/1.75	5.25	16.8	Quince*	3/4/1.75	5.25	16.8
Jupiter	7/2.25	6.75	27.8	Boron	7/2.25	6.75	27.8	Amethyst	7/2.25	6.75	27.8				
Leo	7/2.50	7.50	34.4	Chlorine	7/2.50	7.50	34.4	Diamond	7/2.50	7.50	34.4	Almond	6/1/2.50	7.50	34.4
												Raisin*	3/4/2.50	7.50	34.4
Leonids	7/2.75	8.25	41.6	Chromium	7/2.75	8.25	41.6	Dolomite	7/2.75	8.25	41.6				
Libra	7/3.00	9.00	49.5	Fluorine	7/3.00	9.00	49.5	Emerald	7/3.00	9.00	49.5	Apple	6/1/3.00	9.00	49.5
												Sultana*	4/3/3.00	9.00	49.5
Mars	7/3.75	11.25	77.3	Helium	7/3.75	11.25	77.3	Garnet	7/3.75	11.25	77.3	Banana	6/1/3.75	11.25	77.3
												Walnut*	4/3/3.75	11.25	77.3
Mercury	7/4.50	13.50	111.3	Hydrogen	7/4.50	13.50	111.3	Jade	7/4.50	13.50	111.3				
Moon	7/4.75	14.25	124.0	Iodine	7/4.75	14.25	124.0	Jasper	7/4.75	14.25	124.0				
												Cherry	6/4.75 7/1.60	14.30	120.4
Neptune	19/3.25	16.25	157.6	Krypton	19/3.25	16.25	157.6	Opal	19/3.25	16.25	157.6				
Orion	19/3.50	17.50	182.8	Lutetium	19/3.50	17.50	182.50	Patronite	19/3.50	17.50	182.50	Grape	30/7/2.50	17.50	181.6
Pluto	19/3.75	18.75	209.8	Neon	19/3.75	18.75	209.8	Pearl	19/3.75	18.75	209.8				
Saturn	37/3.00	21.00	261.5	Nitrogen	37/3.00	21.00	261.5	Ruby	37/3.00	21.00	261.5	Lemon	30/7/3.00	21.00	261.5
Sirius	37/3.25	22.75	306.9	Nobelium	37/3.25	22.75	306.9	Ruthenium	37/3.25	22.75	306.9				
Taurus	19/4.75	23.75	336.7	Oxygen	19/4.75	23.75	336.7	Rutile	19/4.75	23.75	336.7				
												Lime	30/7/3.50	24.50	356.0
Triton	37/3.75	26.25	408.6	Phosphorus	37/3.75	26.25	408.6	Sapphire	37/3.75	26.25	408.6				
												Mango	54/7/3.00	27.00	431.2
Uranus	61/3.25	29.25	506.4	Selenium	61/3.25	29.25	506.4	Spinel	61/3.25	29.5	506.4	Orange	54/7/3.25	29.25	506.4
Ursula	61/3.50	31.50	586.9	Silicon	61/3.50	31.50	586.9	Tantalum	61/3.50	31.50	586.9	Olive	54/7/3.50	31.50	586.9
Venus	61/3.75	33.75	673.7	Sulphur	61/3.75	33.75	673.7	Topaz	61/3.75	33.75	673.7	Paw Paw	54/3.75 19/2.25	33.75	672.0
												Peach	54/4.75 19/2.85	42.75	1078.0
Virgo	91/4.50	49.50	1447.0	Xenon	91/4.50	49.50	1447.0	Zircon	91/4.50	49.50	1447.0				

USEFUL REFERENCE TABLES

TOOL AND DIE SELECTION

STANDARD COPPER LUGS, LINKS, STALKS ETC.						
CONDUCTOR SIZE mm ²	DIE A/F mm	HAND CRIMPERS	HYDRAULIC TOOLS – HEXAGONAL DIES			
			5 TONNE #111	12 TONNE #38A #98 #41AH #98H	22 TONNE #66H	60 TONNE #40B
1.5	-					
2.5	-					
4	-					
6	4.4	#00 #102U		38-44CU		
10	5.7	#18/1	111-5763CU	38-57CU		
16	6.3	#16/1	111-5763CU	38-63CU		
25	7.7	#21/1	111-7792CU	38-77CU		
35	9.2	#22/1	111-7792CU	38-92CU		
50	10.4	#20/1	111-104115CU	38-104CU		
70	11.5		111-104115CU	38-115CU		
95	14.2		111-142165CU	38-142CU		
120	16.5		111-142165CU	38-160CU		
150	18.3			38-183CU		
185	20.0			38-200CU		
240	23.1			38-231CU		
300	26.0			38-260CU		
400	28.1				66-281CU	40-281CU
500	31.0				66-310CU	40-310CU
630	37.0					40-370CU
800	43.2					40-432CU
100	48.0					40-489CU

STANDARD ALUMINIUM AND BI-METAL				
CONDUCTOR SIZE mm ²	DIE A/F mm	HYDRAULIC TOOLS – HEXAGONAL DIES		
		12 TONNE #38A #98A #41AH #98H	60 TONNE #40B	
1.5	-			
2.5	-			
4	-			
6	9.0	38-90AL		
10	9.0	38-90AL		
16	9.0	38-90AL		
25	9.0	38-90AL		
35	9.0	38-90AL		
50	13.2	38-132AL		
70	13.2	38-132AL		
95	17.3	38-173AL		
120	17.3	38-173AL		
150	22.0	38-220AL		
185	22.0	38-220AL		
240	28.4	38-284AL		
300	28.4	38-284AL		
400	39.0		40-390AL	
500	39.0		40-390AL	
630	43.2		40-432AL	
800	43.2		40-525AL	

USEFUL REFERENCE TABLES

NOMINAL CABLE DIMENSIONS

CROSS SECTION AREA mm ²	STRAND NO./WIRE DIA.	O.D. OF CONDUCT	O.D. OF P.V.C. SINGLE CORE CABLE	O.D. OF P.V.C. INS. SINGLE CORE SHEATHED	O.D. OF SINGLE CORE XLPE/PVC	TWO CORE	TWO CORE + EARTH	THREE CORE + EARTH	FOUR CORE + EARTH
1	1/1.13 7/0.40	1.13 1.20	2.8	4.1					
1.5	1/1.38 7/0.50	1.38 1.5	3.2	4.4		9.4			
2.5	7/0.67	2.01	3.7	5.1		10.8			
4	7/0.85	2.55	4.6	6.0		12.2			
6	7/1.04	3.12	5.2	6.6		13.4			
10	7/1.35	4.05	6.1	8.1			16.6	18.1	20.0
16	7/1.70	5.10	7.2	9.3			18.6	20.4	22.6
25	19/1.35	6.75	8.9		11.4		22.1	23.8	26.5
35	19/1.53	7.65	10.1		12.6		24.4	26.5	29.5
50	19/1.78	8.9	11.9		14.1		28.0	30.6	34.3
70	19/2.14	10.70	13.5		16.0		31.5	34.8	39.0
95	37/1.78	12.46	15.9		18.2			39.6	44.6
120	37/2.03	14.21	17.4		20.0			43.3	48.8
150	37/2.25	15.75	19.5		22.2			48.4	54.6
185	37/2.52	17.64			24.4			53.7	60.7
240	61/2.25	20.25			27.4			61.0	69.1
300	61/2.52	22.68			30.3			67.6	76.6
400	61/2.85	25.65			33.8				
500	61/3.20	28.80			35.7				
630	127/2.52	32.76			40.2				

NOMINAL DATA AS SPECIFIED IN AS/NZS 5000 -1 & 2



COMPRESSION TERMINATION THEORY

Utilux crimp lugs, links and stalk lugs are designed to be compatible with Utilux indent tools and hydraulic tools with hexagonal or indent dies. Through this exact matching the resultant terminations achieve a consistently precise compression – neither over stressed nor understressed – to produce the correct indent or hexagonal force.

The crimp is designed to bring all conductors and the connector itself into intimate contact. At the same time, the crimp is designed to avoid any reduction in the cross sectional area of the conductor, with an increased contact area.

BASIC COMPRESSION TERMINATION PRACTICES

1. Strip the cable insulation to the recommended length. Recommended stripping lengths of conductors should correspond to the barrel lengths shown in this catalogue.
2. With non plated copper conductors, scratch brushing may be carried out on the bare copper conductor. On aluminium conductors however, scratch brushing must be carried out. Terminating should be completed as soon as possible after stripping of the insulation.
3. To ensure a reliable termination, the correct connector for a given cable size must be selected. Moreover, the recommended indent tool or hexagon tool and die must also be used. See the various data tables in this catalogue for tooling recommendations.
4. Fit the connector over the stripped conductor and place the connector into the hand or hydraulic tool. Apply the recommended pressure. With hand tools, the crimp is not complete until the jaws meet or the ratchet releases. With hex dies in hydraulic tools, the faces of the die must meet.
5. The number of crimps per connector can vary. Some lugs have markings for crimps, if you require more information please contact Utilux.

TERMINATION RECOMMENDATIONS

The palm contact areas of Utilux lugs are designed to give more than that the surface of lugs are used upon has corresponding contact area. Excessive drilling out of palm holes must be avoided, to ensure that adequate palm contact, heavy gauge washers are recommended. In relation to stalk lugs and consistent with the above, care must be taken to adequately match the stalk diameter of the tunnel or mounting connector, to ensure maximum surface contact area. Bolting torques are listed in the following table.

Bolt Size	Material	Tightening Torque
3/8"	Aluminium	20 Newton Metres
1/2"	Aluminium	40 Newton Metres
M10	Aluminium	20 Newton Metres
M6	Steel	16 Newton Metres
M8	Steel	16 Newton Metres
M10	Steel	20 Newton Metres
M12	Steel	40 Newton Metres
M16	Steel	80 Newton Metres
M20	Steel	100 Newton Metres

FLEXIBLE CABLE CRIMPING

The crimping of connectors onto flexible conductors is problematic due to the large amount of air gaps between conductor strands. This results in a large physical size for a relatively small conductor cross section. Thus the standard size lug for a given area of flexible conductor is usually too small. If a larger size lug is used instead, the standard die for that size lug will not achieve the desired compression.

Indent crimping is not recommended, as the indent may damage the very fine strands of a flexible conductor which may in turn cause connector failure.

Adopting the Utilux "Half Hex" crimping method solves the problem.

This method employs a crimping shape in the form of one half of the standard hexagon shape. The dies used comprise a normal hexagon crimp die, along with a special flat die to give the half hexagon shape. The hexagon die is sufficiently large to close around the lug completely, giving adequate compression.

Normally the conductor's area will be known or can be located on the chart below. However if not known, it has to be established. To do this we require the amount of strands and individual strand diameter. Counting the amount of strands is not as daunting a task as it appears. The lay of the conductor will generally be a series of bundled strands, with each bundle having the same lay as a regular laid conductor, eg 7, 19, 37 strands etc. Having established the amount of strands to a bundle, count the amount of bundles and multiply. For example for a 95mm² the conductor may be 259/0.7 with a nominal diameter of 13.8mm, from this the true area is 99.7mm². The diameter is too large for a 95mm² barrel but will fit a 120mm² barrel. It can then be crimped using the half hex method.

Rule of thumb for matching conductor to lug, providing conductor diameter allows, is whatever the area of the conductor, choose the next size larger lug.

CSA mm ²	NO & DIA OF WIRES	OD OF CONDUCTOR	CALCULATED CSA mm ²
16	128/0.4		
	540/0.2	5.8	15.8
25	209/0.4		
	770/0.2	7.5	24.2
35	285/0.4		
	1083/0.2	8.6	34.0
50	380/0.4		
	1558/0.2	10.5	49.0
70	203/0.67		
	2204/0.2	11.6	69.3
95	259/0.67		
	2983/0.2	14.8	93.7
120	336/0.67		
	3810/0.2	15.9	119.7
150	427/0.67		
	4773/0.2	18.6	150.0
185	528/0.67		
	5881/0.2		184.8
240	5920/0.21	18.8	205.1
	672/0.67		
300	7400/0.21	23.7	256.3
	73630/0.2		239.7
400	8911/0.2		280.0
	9102/0.21	26.6	315.3
400	11970/0.2		376.1
	12672/0.21	30.8	438.9

UTILUX CRIMP LUG PART NUMBER		FLEXIBLE CONDUCTOR SIZE (mm ²)			UTILUX HALF HEX SET PART NUMBER	UTILUX HALF HEX DIE SET CONSISTS OF	RECOMMENDED UTILUX TOOLING
		NOMINAL	RANGE				
			MIN	MAX			
H1415A	M6	16	15	19.3	38-98HHEX17/1	Half 38-98CU plus 38-FLAT17	
H1415	M8						
H1416	M10						
H1416A	M11						
H1416B	M12						
H1365	M6	25	23.5	30.5	38-122HHEX17/1	Half 38-122CU plus 38-FLAT17	
H1366	M8						
H1368	M10						
H1369	M12						
H1419	M6	35	27.5	35	38-130HHEX17/1	Half 38-130CU plus 38-FLAT17	
H1420	M8						
H1421	M10						
H1422B	M6	50	47.5	58	38-153HHEX17/1	Half 38-153CU plus 38-FLAT17	
H1422A	M8						
H1422	M10						
H1423	M12						
H1423A	M16						
H1424B	M6	70	66.5	82	38-183HHEX14/1	Half 38-183CU plus 38-FLAT14	
H1424C	M8						
H1424	M10						
H1425	M12						
H1440	M16						
H1438	M20						
H1381	M10	95	89.5	112.5	38-220HHEX14/1	Half 38-220CU plus 38-FLAT14	
H1382	M12						
H1383	M16						
H1382B	M20						
H1384A	M10	120	113.5	141.5	38-245HHEX14/1	Half 38-245CU plus 38-FLAT14	
H1384	M12						
H1385	M16						
H1386	M20						
H1387A	M10	150	131	162.5	40-260HHEX25/1	Half 40-260CU plus 40-FLAT25	
H1387	M12						
H1388	M16						
H1389	M20						
H1390	MB	185	174.5	219.5	40-310HHEX25/1	Half 40-310CU plus 40-FLAT25	
H1390D	M10						
H1390A	M12						
H1390B	M16						
H1390C	M20						
H1391	MB	240	226.5	283.5	40-340HHEX25/1	Half 40-340CU plus 40-FLAT25	
H1391A	M16						
H1391B	M20						
H1448	MB	300	266	330.5	40-370HHEX25/1	Half 40-370CU plus 40-FLAT25	
H1448A	M16						
H1448B	M20						
H1449	MB	400	381.5	460	40-410HHEX25/1	Half 40-410CU plus 40-FLAT25	
H1449A	M16						
H1449B	M20						

Notes:

1. Refer to pages 2 & 3 for copper lug descriptive part numbers
2. To calculate cross sectional area of cable, use following formula;

$$CSA = \frac{N \times d^2 \times \pi}{4}$$

3. Cable chart is for single core double insulated flexible cables 0.6/1kV V90.

METRIC DESCRIPTION

For simplicity in identifying connectors in this catalogue, we have designated certain products with metric coding.

This coding can be used to identify a product if the Utilux catalogue number is unknown.

The following coding applies:

A = Aluminium	K = Link
B = Bi-Metal	S = Sector
C = Copper	M = Palm Hole in mm
G = Lug	MB = Blank Palm
AGS = Aluminium Lug Sector	
AKS = Aluminium Link Sector	
BGS = Bi-Metal Lug Sector	
BKS = Bi-Metal Link Sector	
AG = Aluminium Lug	AK = Aluminium Link
BG = Bi-Metal Lug	BK = Bi-Metal Link
BS = Bi-Metal Stalk	CG = Copper Lug
CK = Copper Link	

The cable area in sqmm and the palm hole is included to complete the description, eg:

(a) BKS70/50 is a Bi-Metal Link Sector, 70mm² solid aluminium to 50mm² stranded copper.

(b) AGS300/M16 is an Aluminium Lug Sector Cable 300mm² solid 16mm palm hole.

(c) AKS240 is an Aluminium Link Sector Cable 240mm² solid.

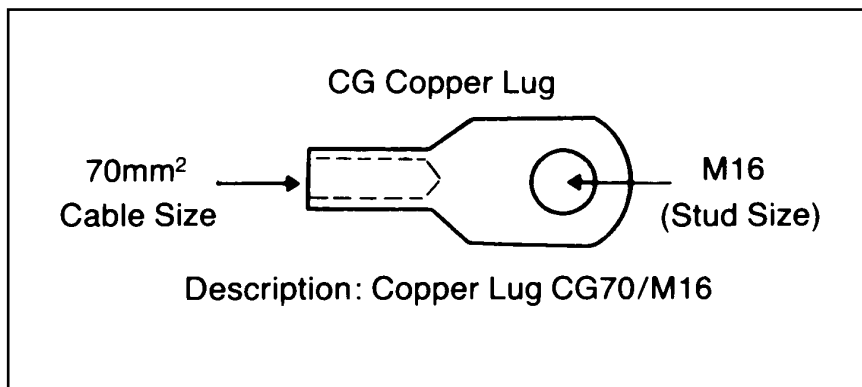

Note: This guide covers a wide, but not exhaustive, range of our products. If you have a special requirement it may be available in our extensive non standard range or, through our Utilux Express service. Please discuss with your Utilux distributor.

ERGONOMIC DESIGN –

THE KEY TO SAFE, COMFORTABLE WORK PRACTICE

Poorly designed hand tools can often cause strain injury to the hands or lower arm and, at best, can make repetitive tasks tiring and uncomfortable. The Utilux range of Ergonomic Design Hand Crimp Tools combines high quality and durable design and manufacture with the best of current ergonomics science for optimal operator safety and comfort. These tools, developed in co-operation with prominent ergonomists, offer maximum performance and user-friendliness. Some important features are;



The optimum grip diameter is the width of the handles measured at the centre of the hand. Tools should be designed so that the maximum force needed is required at the optimum grip diameter.



The shape of the handles offers a comfortable one-hand grip even at maximum opening.



The unique mechanical advantage means that very small forces are required to crimp the connector and cable to fix them in the correct position.



When the connector and cable are fixed, the final crimping can be done with a comfortable two-hand grip.

GOOD MECHANICAL FUNCTION

The lower the hand force required to operate a tool, the lower is the risk of overloading and injury. Utilux Ergonomic Design Tools are equipped with a unique mechanism which reduces the need for muscle force by 45%.

OPTIMUM GRIP DIAMETER

The position at which the hand can transfer most force with minimal stress varies from individual to individual and is also significantly different between men and women. Utilux Ergonomic Design Tools feature handle designs that provide a comfortable optimum grip zone for any operator.

TWO HAND GRIP FEATURE

Our Ergonomic Design Tools feature handles which allow two-hand operation in the final, high force, crimping phase. This dramatically increases crimping force while reducing the possibility of strain or injury.

WEIGHT AND BALANCE

Low weight and good balance are an integral comfort and safety feature of Utilux Ergonomic Design Tools. Handles are precisely shaped to distribute the loading across the palm and four fingers rather than concentrating it on only a few fingers. This distributes surface pressure over the largest possible area of the hand.

HANDLE MATERIAL

Material used for handle grips is carefully selected to exhibit the correct co-efficient of friction when in contact with the skin. This reduces slippage and increases control.

THE HAND – A PRECISION TOOL

The human hand is a powerful, precision tool in its own right. It is our most important means of contact with the environment. But, like any precision instrument, it is sensitive to abuse. The use of quality ergonomically correct tools will help protect this most important part of the human body.