

SECTION 9

CABLE MANAGEMENT AND ASSOCIATED PRODUCTS

The products in this section are used for fastening and bonding.

A large range of pin clips are available for a range of cable bundle diameters. They provide a good means for neatly securing bundles of cable to surfaces. The earth clips provide a quick and secure method for bonding earth conductors. They are made from quality brass and are approved by the Department of Minerals and Energy NSW.

CABLE MANAGEMENT	STYLE	PAGE
	Pin Clip H335B Series	92
	Copper Earth Rod	92
	Earth Clip	92
	Earthing Strap	92
	Cable Holder	93
	Conduit Bender	94
CLIPS	STYLE	PAGE
	Battery Booster Clips	95
	Alligator Clips	95
	Test Clips	95
	Alligator & Test Clip Insulators	95
BAND CLAMPS	STYLE	PAGE
	Stainless Steel Band Clamp & Buckles	96
	Sheathed Band Clamp	96
	Band Clamp Tool	96
	Nylon Band Clamp	97
	Nylon Band Fitting Tool	97
CABLE TIES		PAGE
	Nylon Uti-Ties	98
	Stainless Steel Ties	98
	Nylon Hose Clips	100
CABLE TIE TOOLS		PAGE
	Uti-Tie Tools	99
	Stainless Steel Tie Tool	99

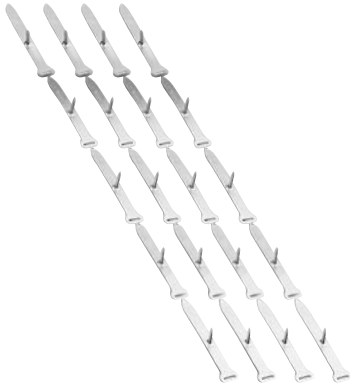

PIN CLIPS

- Manufactured from soft brass, natural finish
- No sharp edges
- Has 12.6mm hardened nail fixed in the pin clip and recessed
- Strips of six for convenient application
- Pin clips are clearly branded and marked with the size number for identification

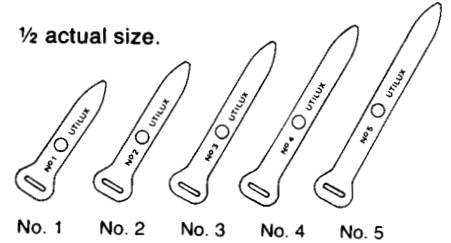

CAT. NO.	MATERIAL	SIZE	LENGTH mm
H335B#1	Brass with hardened nail	1	38
H335B#2	Brass with hardened nail	2	44
H335B#3	Brass with hardened nail	3	51
H335B#4	Brass with hardened nail	4	57
H335B#5	Brass with hardened nail	5	64



COPPER EARTH RODS

CAT. NO.	DESCRIPTION	ROD NOMINAL DIA mm	LENGTH m
CUP1314WC	Domestic – pointed, with clip	13	1.4
CUP1318WC	Domestic – pointed, with clip	13	1.8



EARTH CLIPS

CAT. NO.	MATERIAL	TO SUIT EARTHROD DIA. SIZE mm
H303A#1	Brass	13
H303A#2	Brass	16
H303A#3	Brass	19
H303A#4	Brass	25

EARTHING STRAPS



CAT. NO.	MATERIAL	LENGTH mm
H803A	Brass	101

CABLE HOLDERS

FUNCTION: For securing electrical cable from a diameter of 30mm up to 100mm, to a power pole or beam.

DESIGN FEATURES: The design of the cable holder allows for a variety of sizes of cable, due to the variable adjustment and locking points.

The unique design features of the cable holder are the:

- Dual support legs which allow for dual fixing to a pole
- Optional fixing methods, either using a bolt or bandclamp strapping

MATERIAL: The clamp body is made from mild steel, which has been blanked and formed, then hot-dip galvanised.

- The strap is made from 304 grade stainless steel.
- The pin is zinc diecast.

MARKETS: The clamp has applications in power authorities, mining, railways, building and construction.

ADDITIONAL INFORMATION: A variation to this product is a vertical version, where the fixing points run parallel to the stainless steel strap.

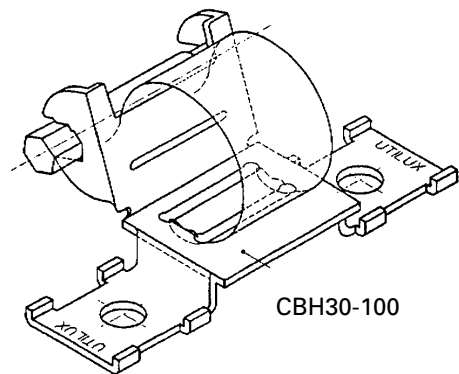

CAT NO.	CABLE	DESCRIPTION
CBH30-100	30-100mm dia	Pole mounted clamp - Horizontal
CBH30-100V	30-100mm dia	Pole mounted clamp - Vertical

CONDUIT BENDERS

The range of Utilux conduit benders are designed for controlled bending of steel conduit and copper pipe without crushing or local deformation occurring.

There are two sizes of bender available, 16mm – 20mm and 25mm. Each bender is made up from two parts, a high strength aluminium head and a galvanised steel handle.



PART NO.	CONDUIT SIZE	DESCRIPTION
AC2071	16-20mm	Head
AC2071H	16-20mm	Handle
AC2081	25mm	Head
AC2081H	25mm	Handle



BATTERY BOOSTER, ALLIGATOR AND TEST CLIPS

BATTERY BOOSTER CLIPS



- All battery clips supplied in equal quantities of positive and negative
 - All clips supplied with handles
 - H811 has a copper shunt between handles
- All clips supplied with copper cable lug, screw and nut

CAT NO.	MATERIAL	MAX. AMPS	JAW OPENING mm
H811	2mm Copper	200	38
H812	2mm Steel Zinc plated	100	38

ALLIGATOR CLIPS



Utilux Battery Charging Clips have a high standard zinc chromate finish suitable for constant potential or series charging

- All clips feature pan head screw to ensure perfect contact

CAT NO.	DESCRIPTION
H141	Nickel Plated brass 5 amp clip
H2790	Nickel Plated brass 5 amp clip with barrel

TEST CLIPS



CAT NO.	DESCRIPTION
H143	25 amp zinc plated steel test clip
H144	50 amp zinc plated steel test clip
H145	10 amp zinc plated steel test clip
H170	15 amp zinc plated steel test clip

ALLIGATOR AND TEST CLIP INSULATORS



INSULATOR FOR	PACKET OF 6 RED & 6 BLACK	PACKET OF 12 RED	PACKET OF 12 BLACK
H170	H2082		
H143		H2083RD	H2083BK
H144	H2084	H2084RD	H2084BK
H2790	H2796	H2796RD	H2796BK

STAINLESS STEEL BAND CLAMP & BUCKLES

- Versatile • Durable • Ease of handling • Low cost
- BAND AND BUCKLES: • stainless steel minimising corrosion • width: 10, 12, 16, 19mm
- supplied in dispensers of 30m • available in matt finish

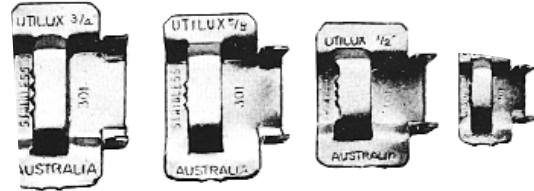

BAND CLAMP – MATT CAT. NO.	WIDTH mm	BUCKLES	TOOLING
H3013M-30	9.5	H3001	#46
H3016M-30	12	H3004	
H3019M-30	16	H3007	
H3022M-30	19	H3010	



SHEATHED BAND CLAMP

- 316 grade stainless steel band clamp
- Coated with halogen free, fire retardant, low smoke compound
- High strength corrosion resistant strapping
- Ideal for applications where safe evacuation, due to a fire could become hazardous

CAT. NO.	WIDTH mm	THICKNESS mm	COATING mm	BUCKLE	TOOLING
H82400-20	12.7	0.95	0.4	H82401	#115

#46 BAND CLAMP TOOL

- Manufactured from high tensile steel
- Machine threaded tension screw
- One tool for all band widths



UTI-TIES

- Durable • Available in natural finish or weather resistant black
- Smooth edges to avoid cuts • Tapered tip for ease of use
- Self locking system resists slippage

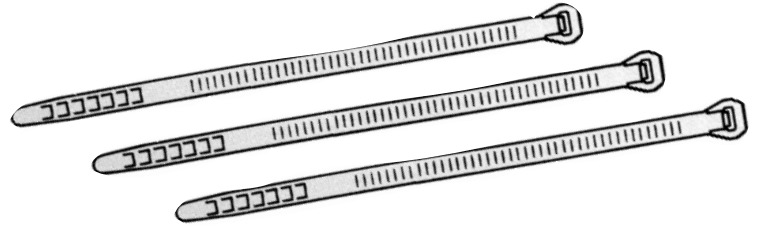

STANDARD NYLON TIES

NATURAL DESCRIPT.	CAT NO.	WEATHER RESISTANT DESCRIPT.	CAT NO.	LENGTH (mm)	WIDTH (mm)	MAX BUNDLE DIA (mm)	TENSILE STRENGTH (KG)	PACK QTY
CT802	H31800	CT802W	H31820	80	2.5	12	8	100/1000
CT1002	H31801	CT1002W	H31821	102	2.5	16	8	100/1000
CT1503	H31802	CT1503W	H31822	150	3.6	32	13	100/1000
CT2004	H31803	CT2004W	H31823	200	4.8	44	22	100/1000
CT3004	H31804	CT3004W	H31824	300	4.8	76	22	100/1000
CT3704	H31806	CT3704W	H31826	370	4.8	102	22	100/1000

HEAVY DUTY NYLON TIES

NATURAL DESCRIPT.	WEATHER RESISTANT DESCRIPT.	LENGTH (mm)	WIDTH (mm)	MAX BUNDLE DIA (mm)	TENSILE STRENGTH (KG)	PACK QTY
CT3807	CT3807W	380	7.6	102	54	100/1000
	CT5507W	550	7.6	160	54	100/1000

EXTRA HEAVY DUTY NYLON TIES

DESCRIPT.	LENGTH (mm)	WIDTH (mm)	MAX BUNDLE DIA (mm)	TENSILE STRENGTH (KG)	PACK QTY
CT55012W	550	12.7	160	110	100

STAINLESS STEEL CABLE TIES

DESCRIPT.	LENGTH (mm)	WIDTH (mm)	MAX BUNDLE DIA (mm)	TENSILE STRENGTH (KG)	PACK QTY
CT2004SS	200	4.6	50	44	100
CT3604SS	360	4.6	100	44	100
CT5204SS	520	4.6	150	44	100
CT6804SS	680	4.6	200	44	100

STAINLESS STEEL CABLE TIES – HEAVY DUTY

DESCRIPT.	LENGTH (mm)	WIDTH (mm)	MAX BUNDLE DIA (mm)	TENSILE STRENGTH (KG)	PACK QTY
CT2008SS	200	8	50	111	50
CT3608SS	360	8	100	111	50

CABLE TIE MOUNTS - 4 WAY

DESCRIPT.	LENGTH (mm)	WIDTH (mm)	HEIGHT	PACK QTY
TM19194	19	19	4	100
TM28284	28	28	4	100

UTI-TIE INSTALLATION TOOL #101

DESCRIPTION

FEATURES Budget, Light weight
 RANGE Suitable for 2 to 5mm wide Uti-Ties
 SIZE 175mm
 WEIGHT 60g

UTI-TIE INSTALLATION TOOL #68

DESCRIPTION

FEATURES Heavy duty steel, manual cut off
 RANGE Suitable for 2.5 to 10mm wide Uti Ties
 SIZE 190mm
 WEIGHT 320g

UTI-TIE INSTALLATION TOOL #69

DESCRIPTION

FEATURES Robust, Tension adjusting dial, auto cut off
 RANGE Suitable for 2 to 4.8mm wide Uti-Ties
 SIZE 165mm
 WEIGHT 210g

STAINLESS STEEL CABLE TIE TENSIONER #116

DESCRIPTION

FEATURES Manual cut off
 RANGE Suitable for all stainless steel ties
 SIZE 210mm
 WEIGHT 570g